



Scientific quarterly journal ISSN 1429-7264

Agricultural Engineering

2014:1(149):111-118

Homepage: <http://ir.ptir.org>



DOI: <http://dx.medra.org/10.14654/ir.2014.149.012>

DETERMINATION OF SEPARATION POTENTIAL OF PEA SEEDS TO BE USED AS SOWING MATERIAL BASED ON DIFFERENCES IN EXTERNAL FRICTION COEFFICIENTS

Agnieszka Markowska^{a*}, Stanisław Konopka^b, Małgorzata Cieślak^c

^aDepartment of Safety Foundations, University of Warmia and Mazury in Olsztyn

^bDepartment of Working Machines and Methodology of Research, University of Warmia and Mazury in Olsztyn

^cScientific Department of Unconventional Techniques and Textiles, Textile Research Institute in Lodz

*Contact details: Jana Heweliusza 10, 10-724 Olsztyn, e-mail: agnieszka.markowska@uwm.edu.pl

ARTICLE INFO

Article history:

Received: November 2013

Received in the revised form:

December 2013

Accepted: January 2014

Key words:

Pea

germination ability

separating properties

ABSTRACT

The paper presents research results concerning differences in basic separating features of batches of pea, which enable efficient separation of material fractions of high germination ability. It was found out that based on differences in such properties, such as: dimensions, mass and critical velocity of lifting seeds, this technological operation may not be sufficiently carried out. In order to solve a practical problem, an attempt was made to determine possible differences in external friction coefficients of seeds on bases made of: steel, gum, cotton, linen, polar and cotton-linen. It was determined that statistically significant differences for this feature occur only for steel. It was suggested that in practice for selection of pea seeds of high germination ability, a 'fighting' [screw conveyor] should be used.

Introduction

Pea (*Pisum sativum L.*) is an annual plant from the Fabaceae family that has been cultivated in temperate climate since ancient times (Grudnik, 2005). Seeds and young pods are the edible parts. Apart from taste characteristics, this vegetable is a valuable source of protein, carbohydrates, mineral salts and vitamins (Gumienna et al., 2006). Lee et al. (2008) demonstrated that legumes are capable of reducing blood pressure. Compared to other leguminous plants, pea contains more potassium, magnesium, iron, and zinc with a lower content of sodium (Grela et al., 2005). Niehues et al. (2010) showed that bioactive peptides of pea (*Pisum sativum L.*) proteins may be used as a component of functional food that protects children against infections such as *Helicobacter pylori*. Pea demonstrates uneven maturation that starts from pods located in the lowest parts of the plant and then moves upwards. When the lowest pods become mature, a two-phase harvest should begin; such procedure involves cutting plants and leaving them on frames for drying, or a one-phase

harvest with desiccation should be initiated. A one-phase harvest without desiccation may result in a substantial loss of seeds. After harvesting, pea seeds are further dried up to 14% of humidity. Depending on cultivation conditions, the yielding of this plant ranges from three to approximately eight tonnes per hectare (Doré et al., 1998).

Initial analysis of the tested material

The study was carried out with cv. “Cud Kelvedonu” pea seeds provided by “Przedsiębiorstwo Nasiennictwa Ogrodniczego i Szkółkarstwa S.A. TORSEED” located in Toruń. These included three samples of 1 kg each, packed in paper (brand) bags and sealed. The samples were prepared by the employees of the company’s laboratory. Information on the packages indicated that these seeds were destined for sowing and that they originated from a single batch (delivered by a farmer to the above-mentioned company). This presented a serious problem to the company, as the material that was treated in the K-541 Petkus treatment facility had an average germination power of approximately 53%. The required germination power of pea seeds destined for sowing should be at least 80% (Michalik and Weiner, 2004). The selected samples differed in seed germination power of 37%, 53% and 65%, respectively.

The delivered seed samples were subjected to an initial analysis in the laboratory at the Department of Working Machines and Research Methodology, University of Warmia and Mazury in Olsztyn. The seed humidity in the individual samples was determined with the drying method (according to PN-91/A-74010) and ranged from 8.3-9.6%. As the range of changes in humidity was insignificant, it was assumed that humidity would not have a significant impact on the results of subsequent measurements.

In addition, max. 0.3 kg of seeds was selected from the sample with the highest germination power (65%); the average germination power after 8 days was approximately 97%. This fraction constituted the so-called “fourth sample” for further experiments.

Further experiments involved a determination of differences in the basic separation parameters that are applied in industrial technological procedures associated with the cleaning of seed mixtures (Grochowicz, 1994). To this end, 300 seeds from each sample were randomly selected and the average values of the following parameters were determined: single seed mass, basic dimensions (length, width and thickness) and critical drift velocities in the vertical air stream.

This data was statistically processed. The basic statistical parameters (mean, standard deviation and minimal random sample size) were determined and the analysis of variance for the average values of individual traits was performed to identify statistically significant differences. In case of such differences, a “post-hoc” Duncan’s test was applied to distinguish the so-called “homogenous” groups. Statistica v. 10 statistical software package was used for calculations and hypotheses testing performed at $\alpha=0.05$ (the level of significance) (Greń, 1984; Rabiej, 2012). The results are presented in table 1.

Determination of the potential...

Tabela 1

The list of statistical analyses results which characterize basic separating properties of pea seeds of „Cud Kelvedonu”cultivar for trials of various germination ability

Parameter	Germination ability (%)							
	37		53		65		97	
	\bar{X}	<i>S</i>	\bar{X}	<i>S</i>	\bar{X}	<i>S</i>	\bar{X}	<i>S</i>
Length (mm)*	7.17 ^a	0.947	7.71 ^b	0.740	7.99 ^b	0.654	7.92 ^b	0.543
Width (mm)	6.57 ^a	0.859	6.56 ^a	0.742	6.58 ^a	0.688	6.59 ^a	0.605
Thickness (mm)*	6.22 ^a	0.867	5.95 ^b	0.648	5.83 ^b	0.582	5.47 ^b	0.563
Seeds mass (g)*	0.17 ^a	0.034	0.21 ^b	0.036	0.20 ^b	0.031	0.22 ^b	0.019
Critical drift velocity (m·s ⁻¹)*	11.72 ^a	0.119	12.16 ^b	0.2406	12.47 ^c	0.148	12.59 ^c	0.134

\bar{X} – average, *S* – standard deviation, * averages marked with the same letters in a line do not differ statistically (homogenous group)

The calculated minimum sizes for measurements of the individual characteristics ranged from 28 to 284 seeds for each sample. This means that the assumed initial size (of 300 seeds from each sample) was sufficient.

The results of calculations showed minor differences between the average values for a given trait and for different samples. It was found that seeds with a germination power of 37% significantly differed in the average length, thickness, single seed mass and critical drift velocity in the vertical air stream from seeds from the other samples. The average values of the above-mentioned parameters were statistically and significantly lower, except for thickness which was significantly higher.

Significantly higher average values of critical drift velocity were recorded for seeds with germination powers of 65% and 97% – a separate homogenous group. A pneumatic separator would thus allow for separating seeds with a germination power over 65% although it would not be possible to meet the criterion for seed material (Michalik and Weiner, 2004).

To sum up, it was found that based on the above-mentioned separation parameters, it was not possible to effectively separate seeds with high germination power from the analysed batch of pea.

Visual differences in colour and external surface texture in seeds from different samples were a sort of suggestion for further studies on a solution to the described problem. Seeds with the lowest germination power were roughly light yellow in colour and wrinkled to a major degree. Together with the increase in germination power, deformation of seeds was smaller and a change of colour to light green was observed in seeds from the sample with a germination power of 97% (Choszcz et al., 2011). These observations allowed us to prepare a hypothesis assuming significant differences in external friction coefficients in pea seeds with different germination power.

Objective of the study

The objective of the study was to determine potential differences in external friction coefficients over different materials for pea seeds with variable germination power in the context of their potential use in sorting procedures..

Methodology of the study

Measurements of external friction coefficients of pea seeds over different surfaces were taken on a measuring station described by Kaliniewicz and Rawa (2000) and are presented in Figure 1.

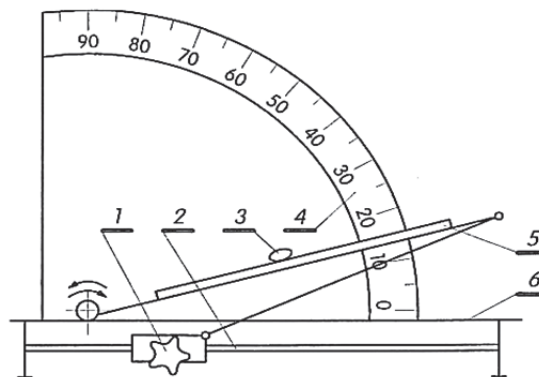

Source: Kaliniewicz i Rawa, 2000

Figure 1. Schematic representation of a device for measuring angles of external friction of loose materials on various bases: 1 – wheel for regulation of tilt angle of a plane, 2 – guidebar, 3 – particle (seed), 4 – protractor, 5 – replaceable base, 6 – base

The measurements involved placing a seed on a replaceable surface in the upper part of a movable arm of the level. The arm of the level was then manually lifted with a knob (1) until the seed started to move over a surface. The angle of elevation for the arm of the level was read from the scale of a protractor (4) to an accuracy of 1°. This angle was transformed according to a relation (1) into the value of static friction coefficient (μ) (Grochowicz, 1994; Kram, 2008)

$$\mu = \operatorname{tg} \beta \quad (-) \quad (1)$$

with the symbol β - denoting the angle of elevation of the level's arm in relation to the surface, (°).

The steps were repeated for subsequent seeds.

The experiments were carried out for the same seeds that were used in the initial studies, whereas the following materials were used as a surface: St3 steel (with roughness at

Determination of the potential...

Ra=0.46 μm), soft rubber without warp (Ra=0.24 μm) and linen (cotton, flax, fleece and cotton-flax). A relatively large assortment of linen types resulted from the assumption to use the so-called inclined belt seed separator for seed separation. The basic characteristics of the above-mentioned linen types are presented in table 2.

Table 2
The list of parameters of canvas structure

Kind of material	Thread density (the number of threads per 10 cm)		Surface mass ($\text{g}\cdot\text{m}^{-2}$)	Type of material	
	Warp	Woof		Warp	Woof
Cotton – fabric, plain weave	240	155	126	Cotton	Cotton
Linen – fabric, plain weave	240	150	140	Flax	Flax
Polar – double sided fleece fabric	-	-	244	Polyester	
Cotton-linen – fabric, plain weave	200	125	256	Cotton	Cotton-flax

The analogous calculation procedures as the ones described in the section on the initial analysis of the tested material were applied to compare the significance of differences between the average friction coefficient values.

Results and their analysis

The average values of friction coefficients depicted in figure 2 and their standard deviations (“whiskers”) for different materials used as the surface indicate that the highest values of this parameter (regardless of germination power) were recorded on fleece linen. These values differed statistically and significantly from the average values of friction coefficients for the other material types. Considerable differences in this parameter were also recorded for such materials as steel, rubber and cotton-flax linen.

No statistical differences between the average values of friction coefficient for particles over cotton and flax linen (for given germination power values) were observed, although they constituted a separate group in relation to the other surface materials.

However, for practical reasons, the differences in the discussed parameter for a given material are most important. The detailed results of the comparisons are presented in table 3.

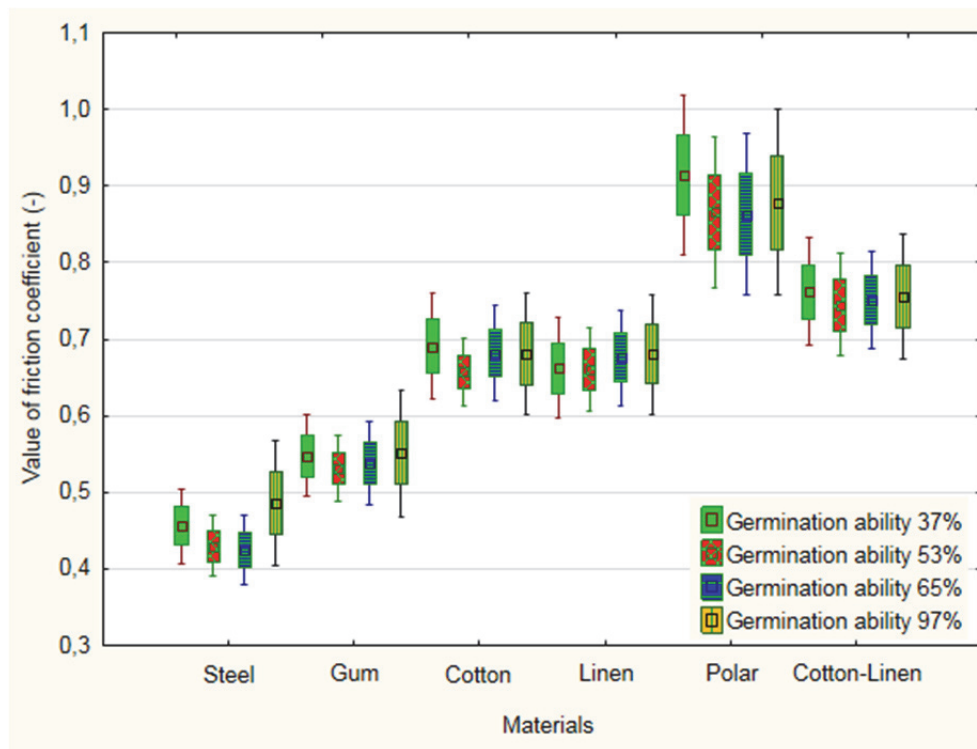

Figure 2. A box plot which illustrates variability of average values and standard deviations of external friction coefficients of pea seeds of various germination ability on the selected materials

Table 3

The list of results of analysis of variance and 'post-hoc' tests for coefficients of pea seeds friction on the selected bases

Germination ability (%)	Steel		Gum		Canvas							
	\bar{X}	<i>S</i>	\bar{X}	<i>S</i>	Cotton		Linen		Micro fleece		Cotton-Linen	
	\bar{X}	<i>S</i>	\bar{X}	<i>S</i>	\bar{X}	<i>S</i>	\bar{X}	<i>S</i>	\bar{X}	<i>S</i>	\bar{X}	<i>S</i>
37	0.46 ^a	0.046	0.55 ^{a,c}	0.067	0.69 ^a	0.086	0.66 ^a	0.082	0.91 ^a	0.131	0.75 ^a	0.077
53	0.43 ^b	0.041	0.53 ^b	0.053	0.66 ^b	0.054	0.66 ^a	0.068	0.87 ^b	0.124	0.73 ^b	0.075
65	0.42 ^b	0.042	0.54 ^{a,b}	0.068	0.68 ^a	0.077	0.67 ^b	0.078	0.86 ^b	0.132	0.74 ^{a,b}	0.076
97	0.49 ^c	0.048	0.55 ^c	0.103	0.68 ^a	0.101	0.68 ^b	0.097	0.87 ^b	0.151	0.74 ^{a,b}	0.077

\bar{X} – average, *S* – standard deviation, * averages marked with the same letters in a line do not differ statistically (homogenous group)

While analysing the data in Table 3, it may be concluded that only steel is a material that permits separation of pea seeds with the highest germination power as far as the differences in external friction coefficients are concerned. The average value of external

friction coefficient (μ) for this surface and pea seeds with a germination power of 97% was 0.49. This value differed significantly from the average values of this parameter for seeds with lower germination power (a separate homogenous group).

No analogous relation was recorded for the other materials included in the study.

Conclusions

Based on the results of the study and calculations, it may be concluded that separation of the fraction of seeds with high germination power from the analysed batch of sowable material is an extremely difficult technological procedure, which results from a lack of differences in the basic separation characteristics, such as dimensions (length, width and thickness), mass and critical drift velocity in the vertical air stream.

The hypothesis (verified in this study) on the differences in external friction coefficients between seeds with different germination power, demonstrated that this characteristic has a limited practical applicability. Despite the studies being conducted on many different types of materials (steel, rubber, and cotton, flax, fleece, and cotton-flax linen), statistically significant differences in this parameter were only recorded for steel. The average value of external friction coefficient for seeds with 97% germination power was 0.49 and was much higher than for seeds with lower germination power. Therefore, it is finally concluded that it would be necessary to use the so-called "spiral gravity separator" to separate seeds with high germination power.

References

- Choszcz, D. J.; Jadwisieńczyk K.; Konopka S.; Majkowska-Gadomska J. (2011). Próba odseparowania z materiału siewnego nasion grochu o niskiej zdolności kiełkowania. *Inżynieria Rolnicza*, 5(130), 39-45.
- Doré, T.; Meynard, J.M.; Sebillotte, M. (1998). The role of drain number, nitrogen nutrition and stem number in limiting pea crop (*Pisum sativum*) yields under agricultural conditions. *European Journal of Agronomy*, 8(3), 29-37.
- Grela, E.R.; Rybiński, W.; Nalewajko, B.; Kowalczyk, E. (2005). Zawartość składników mineralnych w nasionach nowych odmian roślin strączkowych stosowanych w żywieniu ludzi. *Żywnie Człowieka i Metabolizm*, 32 (Suplement 1 - Cz. I), 244-248.
- Greń, J. (1984). *Statystyka matematyczna. Modele i zadania*. Warszawa, PWN, ISBN 83-01-03699-0.
- Grochowicz, J. (1994). *Maszyny do czyszczenia i sortowania nasion*. Lublin, Wyd. AR w Lublinie, ISBN: 83-901612-9-X.
- Grudnik, P. (2005). Technologia uprawy grochu. *Hasło Ogrodnicze*, 4, 155-158.
- Gumienna, M.; Czarnecka, M.; Czarnecki, Z. (2006). Wpływ warunków przechowywania produktów otrzymanych z nasion roślin strączkowych na zmiany aktywności antyoksydacyjnej. *Bromatologia i Chemia Toksykologiczna*, 38(6), 183-188.
- Kaliniewicz, Z.; Rawa, T. (2000). *Laboratorium z maszyn rolniczych*. Olsztyn, Wyd. Uniwersytetu Warmińskiego - Mazurskiego w Olsztynie, ISBN 83-88343-18-1.
- Kram, B.B. (2008). Badania współczynnika tarcia zewnętrznego i kąta naturalnego usypu nasion łubinu odmian Bar i Radames. *Inżynieria Rolnicza*, 4(102), 423-430.
- Lee, Y.P.; Pudney, I.; Hodgson, J. (2008). Protein, fibre and blood pressure: potential benefit of legumes. *Clinical and Experimental Pharmacology and Physiology*, 35, 473-476.

- Michalik, B.; Weiner W. (red.). (2004). *Wybrane zagadnienia z nasiennictwa roślin ogrodniczych*. Kraków, Wyd. Sekcja Hodowli Roślin i Nasiennictwa PTNO, ISBN 83-905196-3-1.
- Niehues, M.; Euler, M.; Georgi, G.; Mank, M.; Stahl, B.; Hensel, A. (2010). Peptides from *Pisum sativum* L. enzymatic protein digest with anti-adhesive activity against *Helicobacter pylori*: Structure-activity and inhibitory activity against BabA, SabA, HpaA and a fibronectin-binding adhesin. *Molecular Nutrition and Food Research*, 54(12), 1851-1861.
- PN-91/A-74010:1991. *Ziarno zbóż i przetwory zbożowe. Oznaczanie wilgotności*.
- Rabiej, M. (2012). *Statystyka z programem Statistica*. Gliwice, Wyd. Helion, ISBN: 978-83-246-4110-9.

OKREŚLENIE MOŻLIWOŚCI WYDZIELANIA NASION GROCHU PRZEZNACZONYCH NA MATERIAŁ SIEWNY PRZY WYKORZYSTANIU RÓŻNIC WE WSPÓŁCZYNNIKACH TARCIA ZEWNĘTRZNEGO

Streszczenie. W pracy przedstawiono wyniki badań dotyczące określenia różnic w podstawowych cechach rozdzielczych partii nasion grochu siewnego, umożliwiających skuteczne wydzielenie frakcji materiału o wysokiej zdolności kiełkowania. Stwierdzono, że na podstawie różnic w takich cechach, jak: wymiary, masa oraz krytyczna prędkość unoszenia nasion nie można skutecznie zrealizować tej operacji technologicznej. W celu rozwiązania praktycznego problemu, podjęto próbę określenia potencjalnych różnic we współczynnikach tarcia zewnętrznego nasion po podłożach ze: stali, gumy oraz płótna (bawełnianego, lnianego, polarowego i bawełniano-lnianego). Ustalono, że istotne statystycznie różnice w tej cesze występują tylko dla stali. Zaproponowano, by w praktyce do wydzielenia nasion grochu o wysokiej zdolności kiełkowania zastosować żmijkę.

Słowa kluczowe: nasiona grochu siewnego, zdolność kiełkowania, cechy rozdzielcze